

DECK DESIGN PACKAGE

PROJECT ADDRESS: _____
REVIEW NUMBER: _____

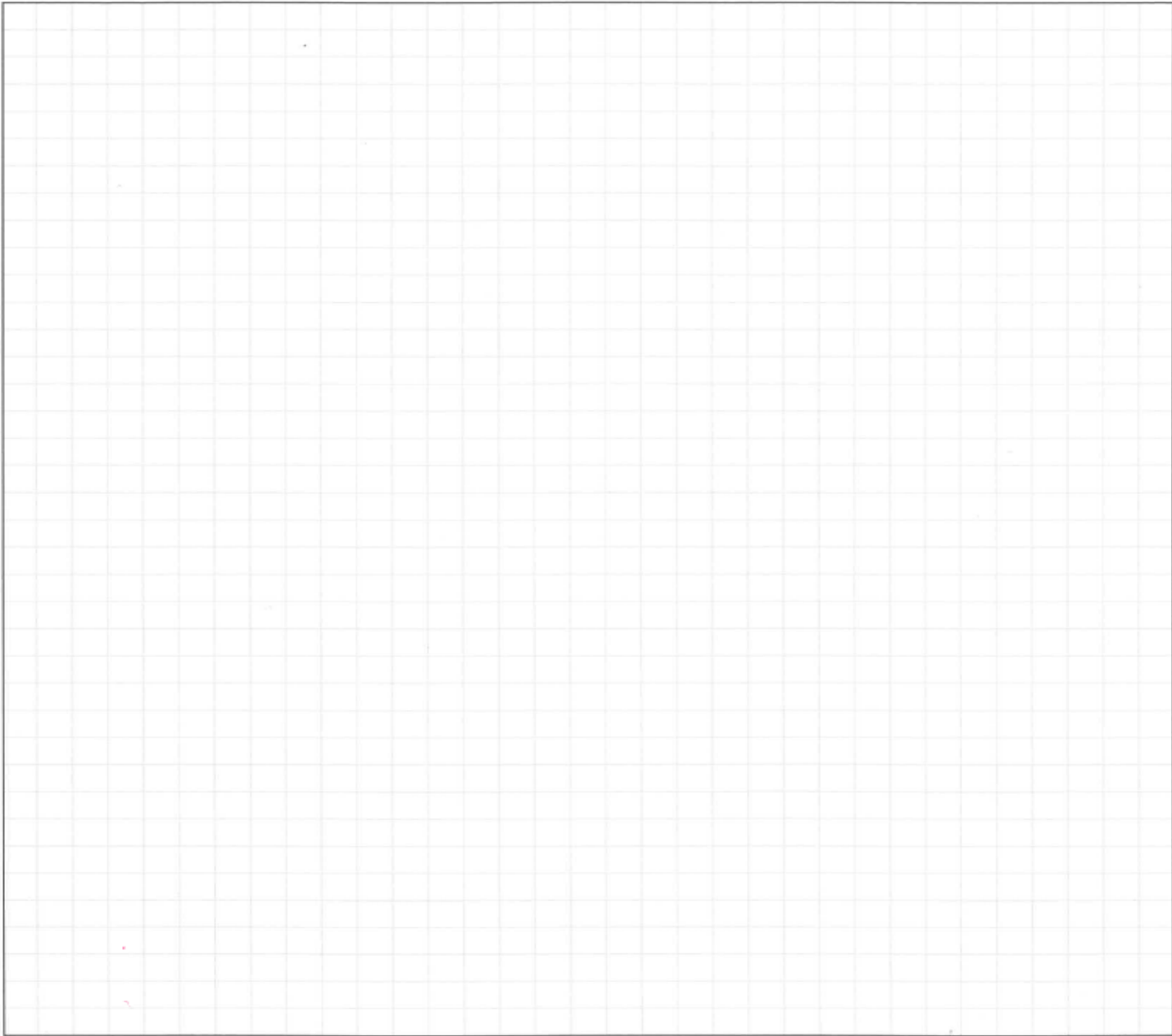

Provide a dimensioned layout of the proposed deck which shows the location of all footings, bearing beams, and installation direction of floor joist.

(Decks supporting large concentrated loads such as hot tubs and large planters are beyond the scope of Section R507 of the 2018 International Residential Code and shall be designed in accordance with accepted engineering practice.)

Footings. Decks shall be supported on concrete footings or other approved structural systems designed to accommodate all loads in accordance with Section R301. Deck footings shall be sized to carry the imposed loads from the deck structure to the ground as shown in IRC Table R507.3.1 or the COK Prescriptive Deck Construction Guide Table R507.3.1 (Simplified)

Minimum Footing Size: _____

Deck post to deck footing connection. Where posts bear on concrete footings in accordance with Section R403 and Figure R507.3, lateral restraint shall be provided by manufactured connectors or a minimum post embedment of 12 inches in surrounding soils or concrete piers.

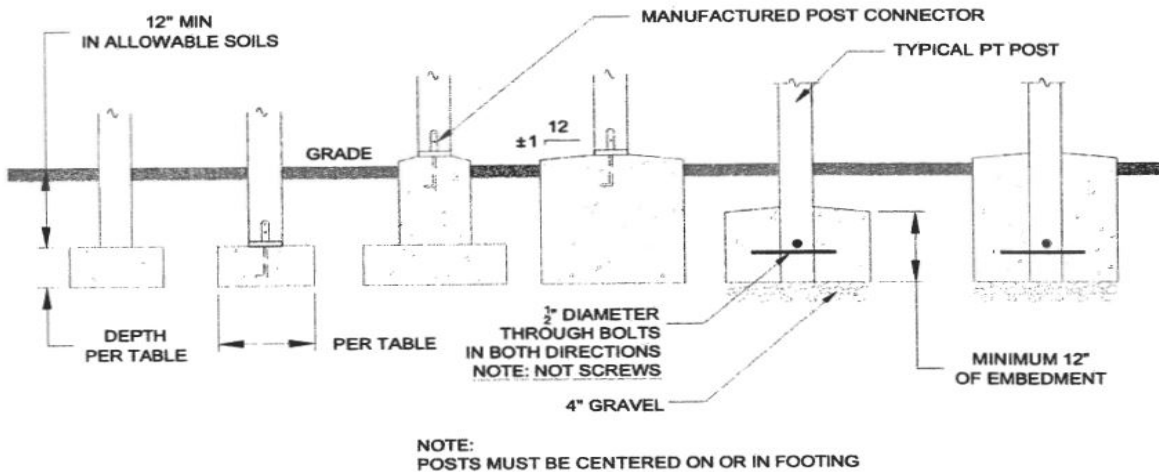

Circle Footing Type / Post-to-Footing Connection to be installed

Deck Beams. Maximum allowable spans for wood deck beams shall be in accordance with Table R507.5.

Species of Lumber and Lumber Size of Beam: _____

Deck beam bearing. The ends of beams shall have not less than 1-1/2 inches of bearing on wood or metal and not less than 3 inches of bearing on concrete or masonry for the entire width of the beam. Where multiple-span beams bear on intermediate posts, each ply must have full bearing on the post in accordance with Figures R507.5.1(1) and R507.5.1(2).

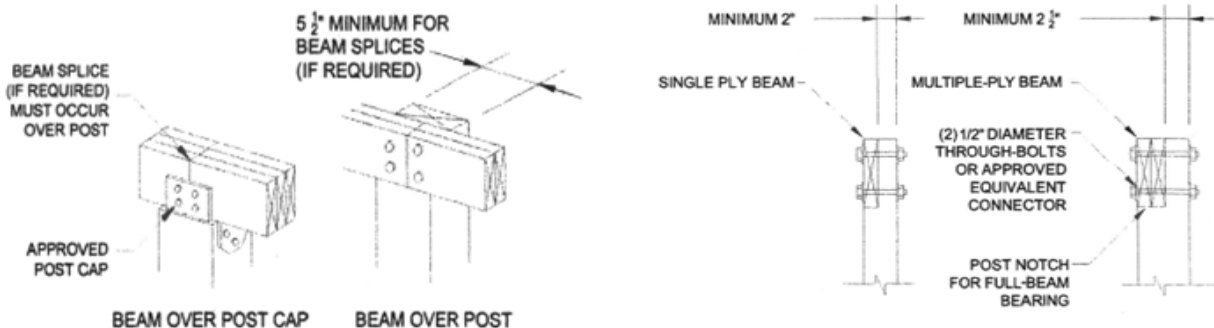

Deck posts. For single-level wood-framed decks with beams sized in accordance with Table R507.5, deck post size shall be in accordance with Table R507.4.

Size and Height of Deck Posts: _____

Deck joists. Maximum allowable spans for wood deck joists shall be in accordance with IRC Table R507.6 or COK Prescriptive Deck Guide Table R507.6.

Joist Species and Grade of Lumber: _____

Joist Size and On-Center Spacing: _____

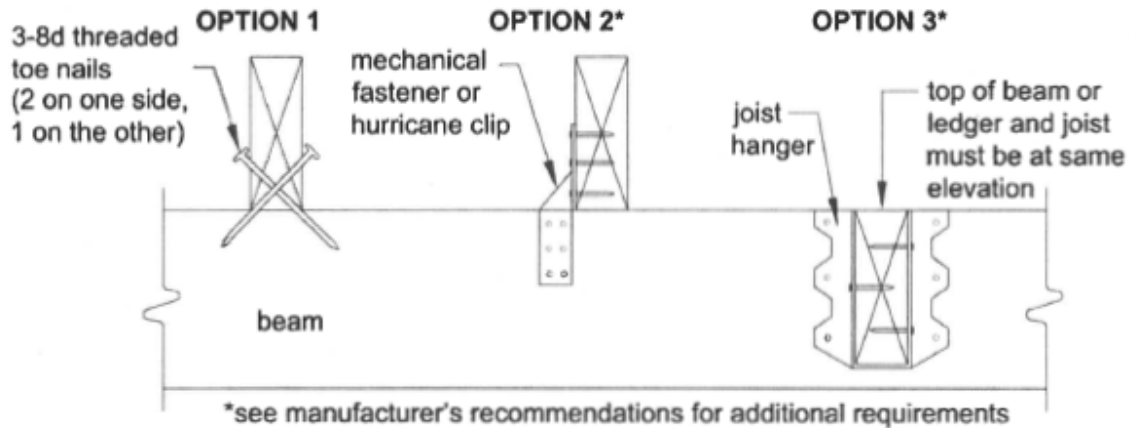

Circle method of joist-to-beam attachment to be used.

Ledger details. Deck ledgers shall be a minimum 2" x 8", pressure-preservative-treated Southern pine, incised pressure-preservative-treated hem-fir, or approved, naturally durable, #2 grade or better lumber.

Deck ledgers shall not support concentrated loads from beams or girders. Deck ledgers shall not be supported on or through stone or masonry veneer.

Ledger connection is directly to the band or rim joist of the house. _____

(initial)

Ledger to band joist details. Fasteners used in deck ledger connections shall be installed in accordance with Table R507.9.1.3(2) and Figures R507.9.1.3(1) and R507.9.1.3(2).

Fastener type and On-Center Spacing of Fastener: _____

Lateral connection. Lateral loads shall be transferred to the ground or to a structure capable of transmitting them to the ground. Where the lateral load connection is provided in accordance with Figure R507.9.2(1), hold-down tension devices shall be installed in not less than two locations per deck, within 24" of each end of the deck. Each device shall have an allowable stress design capacity of not less than 1,500 pounds. Where the lateral load connections are provided in accordance with Figure R507.9.2(2), the hold-down tension devices shall be installed in not less than four locations per deck, and each device shall have an allowable stress design capacity of not less than 750 pounds.

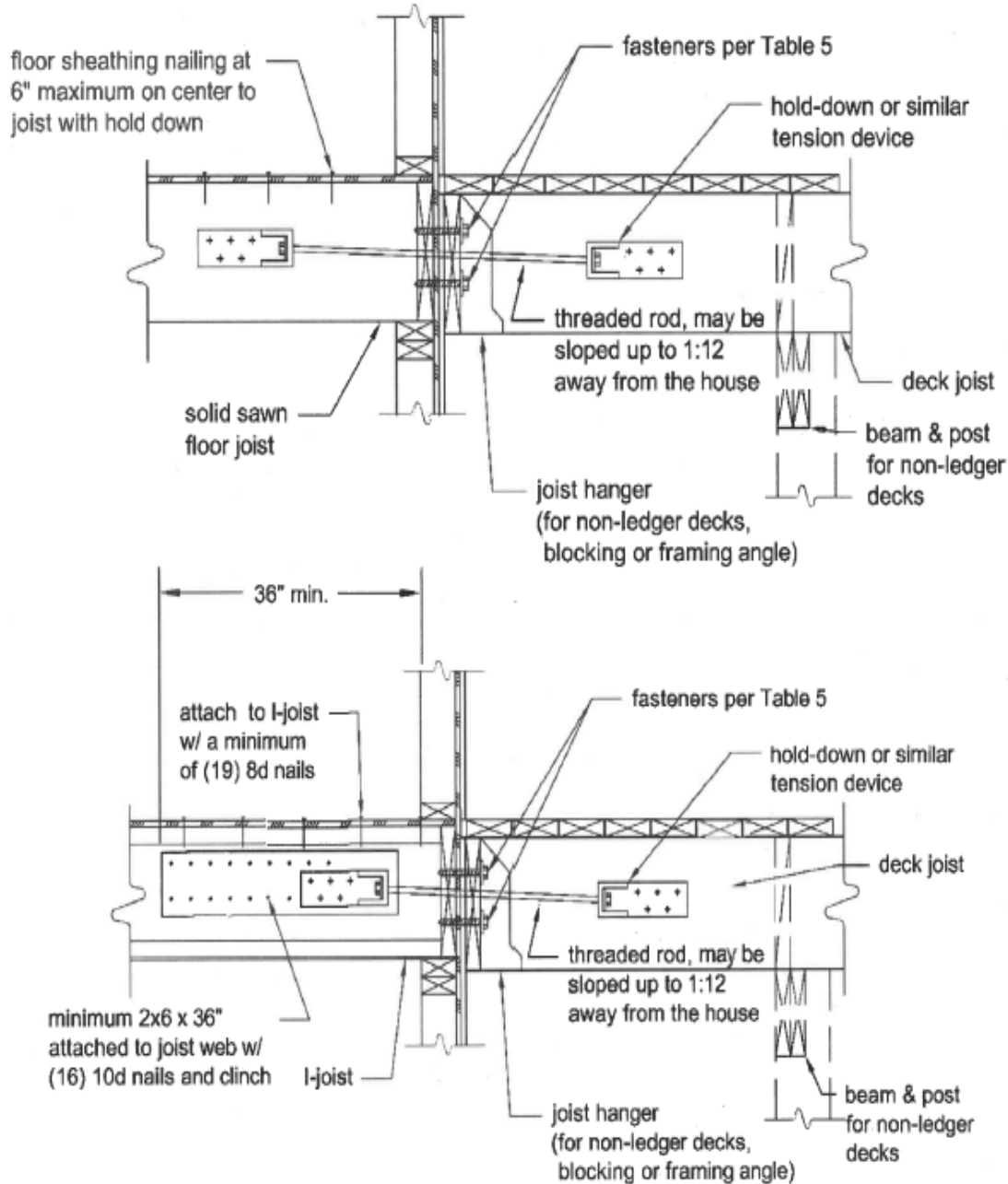

Figure 6
Lateral Load Device Installation – Floor Joist Parallel to Deck Joist

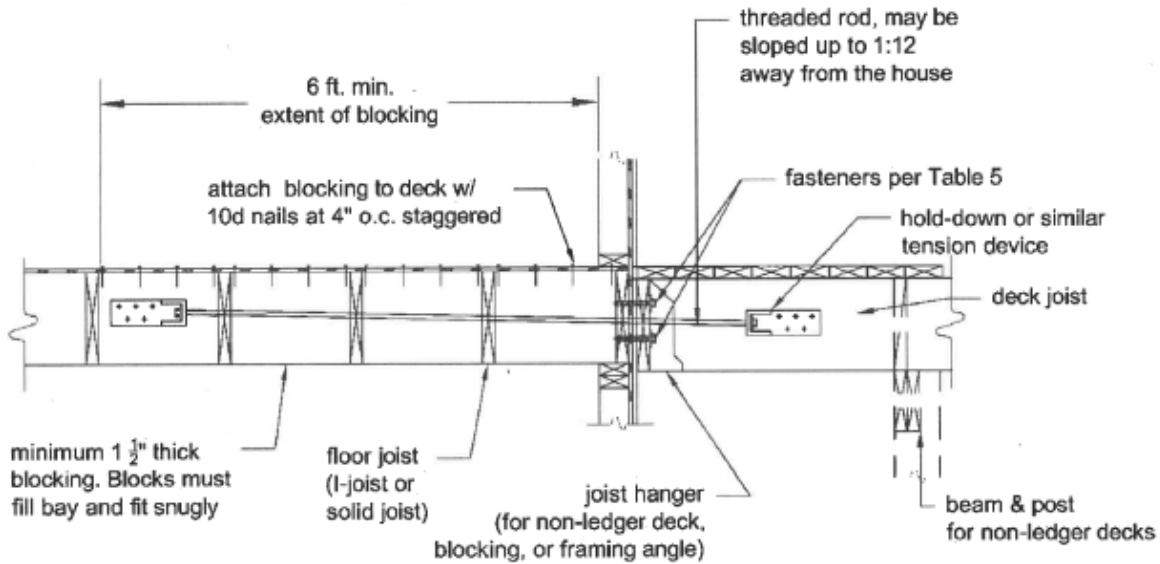

Figure 7
Lateral Load Device Installation – Floor Joist Perpendicular to Deck Joist

Circle method of lateral restraint to be used.

Guards. Guards shall be provided for those portions of open-sided walking surfaces, including stairs, ramps and landings, that are located more than 30" measured vertically to the floor or grade below at any point within 36" horizontally to the edge of the open side. Insect screening shall not be considered as a guard. (See Code for additional requirements)

Stairways. Stairways shall be not less than 36" in clear width, the riser height shall be not more than 7 3/4", and the tread depth shall be not less than 10". There shall be a floor or landing at the top and bottom of each stairway. Graspable handrails shall be provided on not less than one side of each flight of stairs with four or more risers. Handrail ends shall be returned or shall terminate in newel posts or safety terminals. (See Code for additional requirements)

Code compliant Guards and Stairs will be provided. _____
(initial)